

MIDWEST TRUCK EQUIPMENT, INC.

www.mtetrucks.com

**TRUCK AND EQUIPMENT
SALES & SERVICE**

Complete Truck and Trailer Repair
907 2nd Ave W. | WEST FARGO, ND

Call 701-282-3707

www.mtetrucksales.com

service@mtetrucks.com

sales@mtetrucks.com

43 Years In Business

Easy Access off Interstate 94

“Wet Kit Pros”

Midwest truck has a long list of custom built brackets and accessories that make our wet kits stand above the rest. From our premium tanks with available intank or in line filter kits to our variety of kit options like flow diverters, dual pressure pumps, custom hydraulic and PTO controls, just to name a few. This variety lets you get the most out of your investment at the guaranteed lowest price around.



mtetrucksales.com “Your One Stop Truck Shop”

43 Years In Business

PTO's

The first step in any Wet Kit system is the PTO. At MTEI we will research your needs to help get the best fit for your application. We deal direct with the manufactures to get you the best price on a quality product. We offer light, medium and heavy duty product lines.

Our PTO assemblies are available in a variety of ratios and gear sizes to match any application.



We can also custom build a pto for your specific needs to fit almost any vehicle new or old.

mtetrucksales.com **“Your One Stop Truck Shop”**

43 Years In Business

Pumps

A quality Hydraulic pump is the heart of any wet kit system. MTEI stocks a variety of quality new pumps.

High Volume pumps for large cylinders and dump applications



High Pressure pumps for Conveyors and industrial applications

Dual Pressure pumps for multi use applications



mtetrucksales.com **“Your One Stop Truck Shop”**

43 Years In Business

Tanks

Our Fabrication department builds and stocks a variety of tanks from 10 to a 50 gallons with or without in-tank filters.

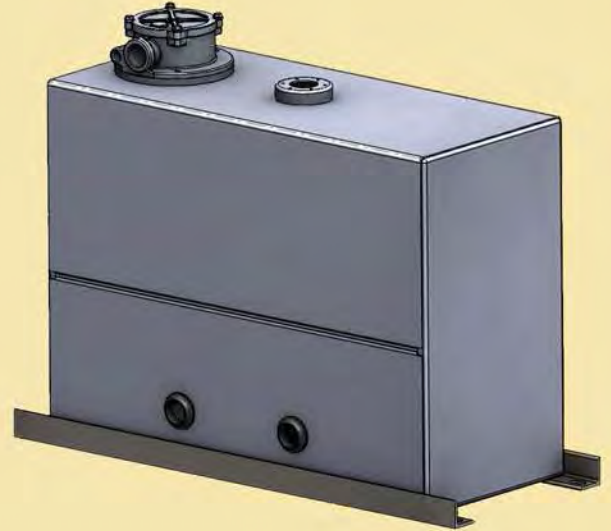

We have both frame and saddle mount tanks available in aluminum and steel to fit your application and budget.



When it comes to cooling we have you covered we can add cooling to an existing system or design you kit with with our Cool Tank.



mtetrucksales.com "Your One Stop Truck Shop"

43 Years In Business

Filters & Valves

MTEI carries quick dump valves, flow diverters, pressure relief and selector valves all to make our wet kits as versatile and user friendly as possible.



Air actuated control valves



Flow Control diverter valves



Manual control valves



Pressure relief valves

In line filters



In tank filters

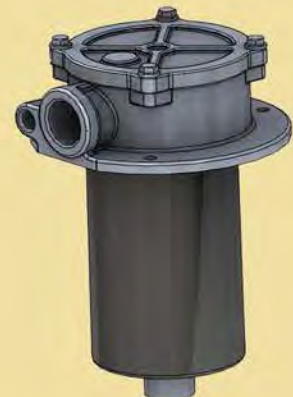

43 Years In Business

Accessories

MTEI Has designed a full line of frame mounted manifolds, cross members tank mounting brackets and universal brackets to give that perfect fit to any installation. Our Brackets are lazer cut and industrial coated for a lifetime of service. Filter bracket options for inside or outside the frame rail, manifolds for single or dual valves, brackets for pump support and control valve mounting. The options are endless.

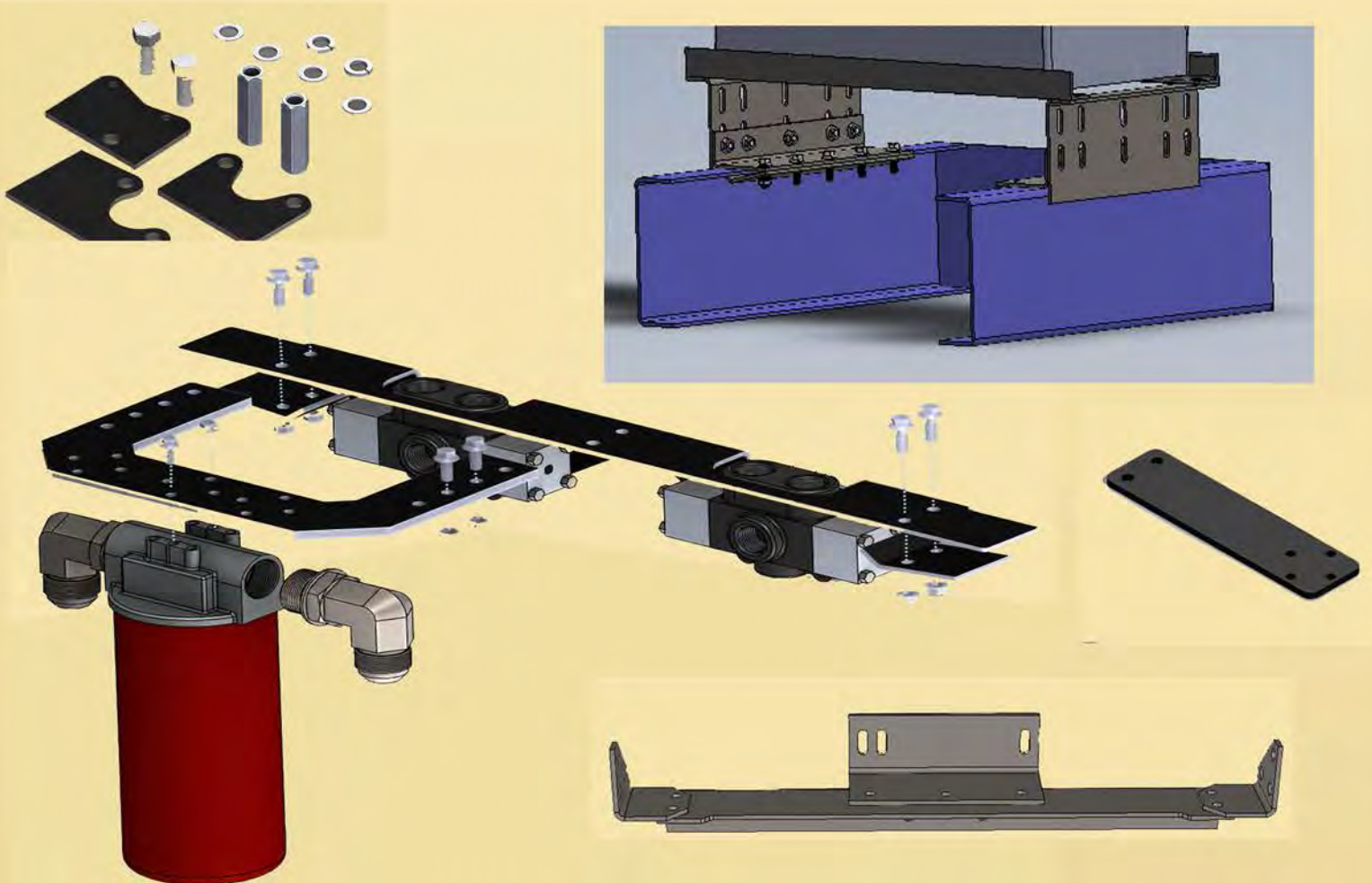

mtetrucksales.com **“Your One Stop Truck Shop”**

43 Years In Business

Hoses And Fittings

MTEI can custom make hoses with dozens of different fitting options in virtually any length. Our high quality hose is a great option for your semi truck, dump trailer, commercial equipment, or farm needs. We also stock a large selection of hydraulic fittings to top off your install.



mtetrucksales.com **“Your One Stop Truck Shop”**